

*Breathe Healthy, Be Healthy.*

**CO  
EXHAUST**







WWW.COEXHAUST.COM

# Price List

Effective from January 2023



This Price list replaces any previous pricelists



**CO  
EXHAUST**

1	Spring return Hose Reels ECONOREEL And SUPERDUTY REEL	
2	Sliding Suction rail	
3	Vehicle Exhaust Nozzles	
4	Direct Drive Exhaust Fans	
5	Swing Booms to extend reach	

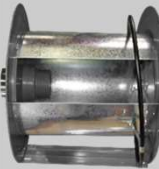
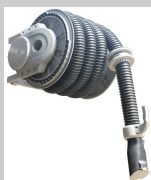
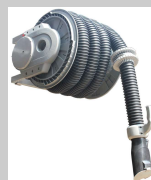

**Vehicle Spring return Exhaust Hose reels**

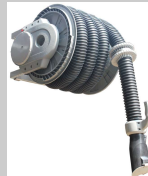
Model	Description		Variation	List Price	Discounted price	Extra ****
	L Spring			Multiplier →	40%	37%
ER-407	ECONOREEL Spring return Exhaust Hose reel Complete with Hose Stop WITHOUT HOSE, Includes Drum , Sheaves, Hose Guide and mounting bracket with 5" (127mm) Outlet <b>Suitable for 25 feet (7 Meters) 4" (102mm) diameter Hose Maximum lift 19kg's (41 lbs)</b>		For4" Hose Internal Code	\$2,094.00	\$837.60	\$774.78
ER-410	ECONOREEL Spring return Exhaust Hose reel Complete with Hose Stop WITHOUT HOSE, Includes Drum , Sheaves, Hose Guide and mounting bracket with 5" (127mm) Outlet <b>Suitable for 33 feet (10 Meters) 4" (102mm) diameter Hose Maximum lift 19kg's (41 lbs)</b>		For 4" Hose	\$2,094.00	\$837.60	\$774.78

ER-507	ECONOREEL Spring return Exhaust Hose reel Complete with Hose Stop WITHOUT HOSE, Includes Drum , Sheaves, Hose Guide and mounting bracket with 5" (127mm) Outlet <b>Suitable for 25 feet (7 Meters) 5" (127mm) diameter Hose Maximum lift 19kg's (41 lbs)</b>		For 5" Hose	\$2,094.00	\$837.60	\$774.78
ER-510	ECONOREEL Spring return Exhaust Hose reel Complete with Hose Stop WITHOUT HOSE, Includes Drum , Sheaves, Hose Guide and mounting bracket with 5" (127mm) Outlet <b>Suitable for 33 feet (10 Meters) 5" (127mm) diameter Hose Maximum lift 19kg's (41 lbs)</b>		For 5" Hose	\$2,094.00	\$837.60	\$774.78
Model	Description		Variation	List Price	Discounted price	Extra ****
SD-407	SUPERDUTY Spring return Exhaust Hose reel Complete with Hose Stop WITHOUT HOSE, Includes Drum , Sheaves, Hose Guide and mounting bracket with 6" (150mm ) Outlet <b>Suitable for 25 feet (7 Meters) 4" (102 mm) diameter Hose Maximum lift 19kg's (41 lbs)</b>		For 4" Hose	\$2,652.00	\$1,060.80	\$981.24
SD-410	SUPERDUTY Spring return Exhaust Hose reel Complete with Hose Stop WITHOUT HOSE, Includes Drum , Sheaves, Hose Guide and mounting bracket with 6" (150mm ) Outlet <b>Suitable for 35 feet (10 Meters) 4" (102mm) diameter Hose Maximum lift 25kg's (54 lbs)</b>		For 5" Hose	\$2,652.00	\$1,060.80	\$981.24
SD-507	SUPERDUTY Spring return Exhaust Hose reel Complete with Hose Stop WITHOUT HOSE, Includes Drum , Sheaves, Hose Guide and mounting bracket with 6" (150mm ) Outlet <b>Suitable for 25 feet (7 Meters) 5" (127mm) diameter Hose Maximum lift 19kg's (41 lbs)</b>		For 5" Hose/ 25 ft	\$2,652.00	#VALUE!	#VALUE!
SD-510	SUPERDUTY Spring return Exhaust Hose reel Complete with Hose Stop WITHOUT HOSE, Includes Drum , Sheaves, Hose Guide and mounting bracket with 6" (150mm ) Outlet <b>Suitable for 33 feet (10 Meters) 5" (127mm) diameter Hose Maximum lift 25kg's (55 lbs)</b>		For 5" Hose/ 25 ft	\$2,652.00	\$1,060.80	\$981.24

SD-610	SUPERDUTY Spring return Exhaust Hose reel Complete with Hose Stop WITHOUT HOSE, Includes Drum , Sheaves, Hose Guide and mounting bracket with 6" (150mm ) Outlet <b>Suitable for 25 feet (7 Meters) 6" (152mm) diameter Hose Maximum lift 25kg's (55 lbs)</b>		For 6" Hose/ 35 ft	\$2,978.00	\$1,191.20	\$1,101.86
SD-610	SUPERDUTY Spring return Exhaust Hose reel Complete with Hose Stop WITHOUT HOSE, Includes Drum , Sheaves, Hose Guide and mounting bracket with 6" (150mm ) Outlet <b>Suitable for 33 feet (10 Meters) 6" (152mm) diameter Hose Maximum lift 25kg's (55 lbs)</b>		For 6" Hose/ 35 ft	\$2,978.00	\$1,191.20	\$1,101.86
Model	Description		Variation	List Price	Discounted price	Extra ****
MO-310	MOTOREEL Motorized Exhaust Hose reel Complete with Hose Stop WITHOUT HOSE, Includes Drum , Sheaves, Hose Guide and motor With remote Control and mounting bracket with 6" (150mm ) Outlet <b>Maximum 35 feet (10 Meters) 6" (152mm) diameter Hose Maximum lift ??kg's (??lbs)</b>		For 4" Hose	\$4,188.00	\$1,675.20	\$1,549.56
MO-410			For 5" Hose	\$4,234.00	\$1,693.60	\$1,566.58
MO-510			For 6" Hose/ 25 ft	\$4,281.00	\$1,712.40	\$1,583.97
MO-610			For 6" Hose/ 35 ft	\$4,374.00	\$1,749.60	\$1,618.38

**Exhaust Hoses**

Model	Description		Variation	List Price/ft	Discounted price	Extra ****
NPF-4	400 degree neoprene coated polyester fabric hose with galvanized steel external helix. Standard lengths 25 feet or 35 feet (7.5 meters or 10 meters)		4" Ø Hose	\$21.00	\$8.40	\$7.77
NPF-5			5" Ø Hose	\$26.00	\$10.40	\$9.62
NPF-6			6" Ø Hose	\$30.00	\$12.00	\$11.10
NPF-8			8" Ø Hose	\$0.00	\$0.00	\$0.00
KEV/NPN-4	2-ply regular temperature black Kevlar / Neoprene blend hose Bronze plated steel wire helix Tight bend radius without twisting but with smooth airflow flexible and lightweight Wear vulcanized wall Temperature +200 °C (3500°F) High tensile strength		4" Ø Hose	\$54.00	\$21.60	\$19.98
KEV/NPN-5			5" Ø Hose	\$67.00	\$26.80	\$24.79
KEV/NPN-6			6" Ø Hose	\$80.00	\$32.00	\$29.60
KEV/NPN-8			8" Ø Hose	\$90.00	\$36.00	\$33.30
KEV/SIL-4	2-ply high temperature black Kevlar / silicone blend hose Bronze plated steel wire helix Tight bend radius without twisting but with smooth airflow flexible and lightweight Wear vulcanized wall Temperature +310 °C (600°F) High tensile strength		4" Ø Hose	\$57.00	\$22.80	\$21.09
KEV/SIL-5			5" Ø Hose	\$71.00	\$28.40	\$26.27
KEV/SIL-6			6" Ø Hose	\$85.00	\$34.00	\$31.45
KEV/SIL-8			8" Ø Hose	\$113.00	\$45.20	\$41.81



**Sliding Exhaust rails**

Model	Description		Variation	List Price	Discounted price	Extra ****
SS-2-5	CoExhaust Suction Rail kits Aluminum Alloy Anti-rust, 130mm diameter. 5kg weight per		6.6 ft length	\$754.00	\$301.60	\$278.98



SS-4-5	meter (3.5lbs per foot) Not including trolley and additional accessories. Standard length 4 meters (13 ft) Includes required hangars, end connections and caps and rubber seal and wall or ceiling mounting brackets . Rails can be joined or cut to suit application		13.1 ft length	\$1,646.00	\$658.40	\$609.02
--------	---	---	----------------	------------	----------	----------



**Accessories for exhaust rails 5" profile**

RT-B-5	Basic trolley for Hose Including rollers and ready for flange connection (please select flange below)			\$1,442.00	\$576.80	\$533.54
FC-3	Connection collar for 3" hose		3" Ø Hose	\$186.00	\$74.40	\$68.82
FC-4	Connection collar for 4" hose		4" Ø Hose	\$186.00	\$74.40	\$68.82
FC-5	Connection collar for 5" hose		5" Ø Hose	\$186.00	\$74.40	\$68.82
FC-6	Connection collar for 6" hose		6" Ø Hose	\$186.00	\$74.40	\$68.82
FC-8	Connection collar for 8" hose		8" Ø Hose	\$186.00	\$74.40	\$68.82
HR-T-5	Trolley for Mounting of Hose reel to rail		N/A	\$2,233.00	\$893.20	\$826.21



**Exhaust rails 6" profile**

SS-2-6	CoExhaust Suction Rail kits Aluminum Alloy Anti-rust, 150mm diameter. 5kg weight per meter (3.5lbs per foot) Not including trolley and additional accessories. Standard length 4 meters (13 ft) Includes required hangars, end connections and caps and rubber seal and wall or ceiling mounting brackets . Rails can be joined or cut to suit application		6.6 ft length	\$1,452.00	\$580.80	\$537.24
SS-4-6			13.1 ft length	\$2,438.00	\$975.20	\$902.06





**Accessories for exhaust rails 6" profile**

RT-B-6	Basic trolley for Hose Including rollers and ready for flange connection (please select flange below)			\$1,442.00	\$576.80	\$533.54
FC-3	Connection collar for 3" hose		3" Ø Hose	\$186.00	\$74.40	\$68.82
FC-4	Connection collar for 4" hose		4" Ø Hose	\$186.00	\$74.40	\$68.82
FC-5	Connection collar for 5" hose		5" Ø Hose	\$186.00	\$74.40	\$68.82
FC-6	Connection collar for 6" hose		6" Ø Hose	\$186.00	\$74.40	\$68.82
FC-8	Connection collar for 8" hose		8" Ø Hose	\$186.00	\$74.40	\$68.82
HR-T-6	Trolley for Mounting of Hose reel to rail		N/A	\$1,442.00	\$576.80	\$533.54







**Vehicle tailpipe Exhaust Nozzles**



Model	Description	Variation	List Price	Discounted price	Extra ****
1-102	Round Inlet 4.75" (120 mm) diameter Single Exhaust With hose connection of 4" (100 mm) And CO analysis tube		\$149.00	\$59.60	\$55.13
2-127	Round Inlet 7" (180mm) SINGLE Exhaust with 5" (125mm) Hose connection And CO analysis tube		\$168.00	\$67.20	\$62.16
2-152	Round Inlet 7" (180mm) SINGLE Exhaust with 6" (150mm) Hose connection And CO analysis tube		\$223.00	\$89.20	\$82.51

3-102	Round Inlet 7" (180mm) SINGLE Exhaust with 4" (102mm) Hose connection And CO analysis tube		\$279.00	\$111.60	\$103.23
3-127	Round Inlet 7" (180mm) SINGLE Exhaust with 5" (125mm) Hose connection And CO analysis tube		\$298.00	\$119.20	\$110.26
4-102	Oval Inlet 7.5" (190mm) x 3"(80mm) diameter Single or dual exhaust 4" (100mm) Hose Connection		\$168.00	\$67.20	\$62.16
5-102	Oval Inlet 8.5" (210mm) x 5"(120mm) diameter Single or dual exhaust 4" (100mm) Hose Connection		\$242.00	\$96.80	\$89.54
6-102	Oval Inlet 8.5" (210mm) x 5"(120mm) diameter Single or dual exhaust 4" (100mm) Hose Connection with handle		\$335.00	\$134.00	\$123.95
7-102	Oval Inlet 6" (150mm) x 4.5"(110mm) diameter Single or dual exhaust 4" (100mm) Hose Connection with handle and spring loaded damper		\$372.00	\$148.80	\$137.64
8-102	Oval Inlet 5" (150mm) x 4.5"(110mm) diameter Single or dual exhaust 4" (100mm) Hose Connection with spring loaded damper		\$242.00	\$96.80	\$89.54
9-127	ROUND Inlet 210mm (8.5" ) Truck exhaust 5" (125mm) Hose connection With Clamp on grip		\$409.00	\$163.60	\$151.33
9-152	ROUND Inlet 210mm (8.5" ) Truck exhaust 6" (150mm) Hose connection With Clamp on grip		\$428.00	\$171.20	\$158.36
10-127	ROUND Inlet 245mm (10" ) Truck exhaust 5" (150mm) Hose connection With Clamp on grip Stainless Steel construction		\$1,117.00	\$446.80	\$413.29
10-152	ROUND Inlet 245mm (10" ) Truck exhaust 6" (150mm) Hose connection With Clamp on grip Stainless Steel construction		\$1,247.00	\$498.80	\$461.39
10-200	ROUND Inlet 245mm (10" ) Truck exhaust 8" (150mm) Hose connection With Clamp on grip Stainless Steel construction		\$1,545.00	\$618.00	\$571.65
11-102	ROUND Inlet 145mm (6" ) T (150mm) 4" (100mm) Hose connection With spring loaded dampered inlet		\$409.00	\$163.60	\$151.33
Model	Description	Variation	List Price	Discounted price	Extra ****
11-127	ROUND Inlet 145mm (6" ) T (150mm) 5" (127mm) Hose connection With spring loaded dampered inlet		\$409.00	\$163.60	\$151.33
11-152	ROUND Inlet 145mm (6" ) T (150mm) 6" (152mm) Hose connection With spring loaded dampered inlet		\$409.00	\$163.60	\$151.33
12-102	ROUND Inlet 120mm (5" ) Truck exhaust 4" (100mm) Hose connection With inside the tailpipe grip		\$354.00	\$141.60	\$130.98

13-102	OVAL Inlet 190mm x 80mm (8"W x 3") diameter Dual exhaust 4" (100mm) Hose connection WITH CO Analysis port and inside the tailpipe grip		\$316.00	\$126.40	\$116.92
14-102	OVAL Inlet 210mm x 120mm (8.5"W x 5") diameter Dual exhaust 4" (100mm) Hose connection WITH CO Analysis port and inside the tailpipe grip		\$391.00	\$156.40	\$144.67
15-102	OVAL Inlet 210mm x 120mm (8.5"W x 5") diameter Dual exhaust 4" (100mm) Hose connection WITH CO Analysis port and inside the tailpipe grip And Handle		\$503.00	\$201.20	\$186.11
16-102	OVAL Inlet 320mm x 116mm (11"W x 4.5") Dual exhaust 4" (100mm) Hose connection WITH CO Analysis port and inside the tailpipe grip and Handle		\$893.00	\$357.20	\$330.41

### Exhaust Fans

Model	Description	Variation	List Price	Discounted price	Extra ****
EF-1-110	CoExhaust Industrial Fan Direct drive 1 HP (.75kw) 3450 RPM motor . Fan with Spark proof Impeller, Stamped Steel housing and Cast Aluminum Impeller complete with motor. 6" inlet and Outlet , Includes Plastic Mesh screen on inlet and outlet to prevent foreign items from entering fan. 110/1/60		\$2,088.00	\$835.20	\$772.56
EF-1-460	CoExhaust Industrial Fan Direct drive 1 HP (.75kw) 3450 RPM motor . Fan with Spark proof Impeller, Stamped Steel housing and Cast Aluminum Impeller complete with motor. 6" inlet and Outlet , Includes Plastic Mesh screen on inlet and outlet to prevent foreign items from entering fan. 460/3/60		\$1,896.00	\$758.40	\$701.52
EF-1-575	CoExhaust Industrial Fan Direct drive 1 HP (.75kw) 3450 RPM motor . Fan with Spark proof Impeller, Stamped Steel housing and Cast Aluminum Impeller complete with motor. 6" inlet and Outlet , Includes Plastic Mesh screen on inlet and outlet to prevent foreign items from entering fan. 575/3/60		\$2,280.00	\$912.00	\$843.60
EF-2-220	CoExhaust Industrial Fan Direct drive 2 HP (1.5kw) 3450 RPM motor . Fan with Spark proof Impeller, Stamped Steel housing and Cast Aluminum Impeller complete with motor. 8" inlet and Outlet , Includes Plastic Mesh screen on inlet and outlet to prevent foreign items from entering fan. 220/1/60 motor		\$3,024.00	\$1,209.60	\$1,118.88
EF-2-460	CoExhaust Industrial Fan Direct drive 2 HP (1.5kw) 3450 RPM motor . Fan with Spark proof Impeller, Stamped Steel housing and Cast Aluminum Impeller complete with motor. 8" inlet and Outlet , Includes Plastic Mesh screen on inlet and outlet to prevent foreign items from entering fan. 460/3/60 motor		\$2,476.00	\$990.40	\$916.12
EF-2-575	CoExhaust Industrial Fan Direct drive 2 HP (1.5kw) 3450 RPM motor . Fan with Spark proof Impeller, Stamped Steel housing and Cast Aluminum Impeller complete with motor. 8" inlet and Outlet , Includes Plastic Mesh screen on inlet and outlet to prevent foreign items from entering fan. 575/3/60 motor		\$3,024.00	\$1,209.60	\$1,118.88

EF-3-460	CoExhaust Industrial Fan Direct drive 3 HP (2,2kw) 3450 RPM motor . Fan with Spark proof Impeller, Stamped Steel housing and Cast Aluminum Impeller complete with motor. 10" inlet and Outlet , Includes Plastic Mesh screen on inlet and outlet to prevent foreign items from entering fan. 460/3/60 motor		\$2,753.00	\$1,101.20	\$1,018.61
EF-3-575	CoExhaust Industrial Fan Direct drive 3 HP (2,2kw) 3450 RPM motor . Fan with Spark proof Impeller, Stamped Steel housing and Cast Aluminum Impeller complete with motor. 10" inlet and Outlet , Includes Plastic Mesh screen on inlet and outlet to prevent foreign items from entering fan. 575/3/60 motor		\$3,024.00	\$1,209.60	\$1,118.88

**EXHAUST FAN ACCESSORIES**

Model	Description	Variation	List Price	Discounted price	Extra ****
EF-1-100	Replacement Cast Aluminum Impeller for 1hp (.75kw) fans		\$354.00	\$141.60	\$130.98
EF-2-100	Replacement Impeller for 2 HP fans (Diameter 250mm x 110mm Height)		\$419.00	\$167.60	\$155.03
EF-3-100	Replacement Impeller for 3 HP fans (300mm Diameter 300mm x 115mm Height)		\$456.00	\$182.40	\$168.72
HR-A1	Fan adapter to mount fan to hose reel		\$279.00	\$111.60	\$103.23
FA-A1	Fan adapter to mount fan to Fume arms		\$456.00	\$182.40	\$168.72
FM-1-220	Replacement Motor 1HP (.75kw) 110/220/1/60		\$832.00	\$332.80	\$307.84
FM-1-460	Replacement Motor 1HP (.75kw) 460/3/60		\$640.00	\$256.00	\$236.80
FM-1-575	Replacement Motor 1HP (.75kw) 575/3/60		\$788.00	\$315.20	\$291.56
	Replacement Motor 2HP (.75kw) 220/1/60		\$808.00	\$323.20	\$298.96
	Replacement Motor 2HP (.75kw) 460/3/60		\$755.00	\$302.00	\$279.35
	Replacement Motor 2HP (.75kw) 575/3/60		\$852.00	\$340.80	\$315.24
	Replacement Motor 3HP (.75kw) 460/3/60		\$863.00	\$345.20	\$319.31
	Replacement Motor 3HP (.75kw) 575/3/60		\$995.00	\$398.00	\$368.15

**Swing Extension Booms**

Model	Description	Variation	List Price	Discounted price	Extra ****
<b>Single Pivot Booms</b>					



<b>SB-5</b>	Econoboomb Single pivot boom 6" diameter 5ft length		\$4,061.00	\$1,624.40	\$1,502.57
<b>SB-10</b>	Econoboomb Single pivot boom 6" diameter 10ft length		\$5,791.00	\$2,316.40	\$2,142.67
<b>SB-15</b>	Econoboomb Single pivot boom 6" diameter 15ft Length		\$7,081.00	\$2,832.40	\$2,619.97

**Double Pivot Booms**

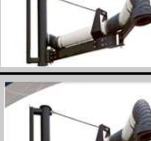
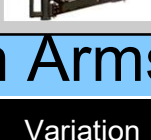
<b>DSB-10</b>	Double Pivot Swing Boom 6" Diameter Tube and Hose Inner 7ft extension and outer 3 ft pivoting extension		\$7,716.00	\$3,086.40	\$2,854.92
<b>DSB-15</b>	Double Pivot Swing Boom 6" Diameter Tube and Hose Inner 10ft extension and outer 5 ft pivoting extension		\$8,062.00	\$3,224.80	\$2,982.94
<b>DSB-20</b>	Double Pivot Swing Boom 6" Diameter Tube and Hose Inner 15ft extension and outer 5 ft pivoting extension		\$8,925.00	\$3,570.00	\$3,302.25

**Fume and Dust Extraction Arms**

Model	Description	Variation	List Price	Discounted price	Extra ****
1620	Fume extraction arm, for capturing dust and fumes in workshops such as grinding and polishing. Includes hood, swivel and mounting bracket. Can be coupled with CoExhaust fans.	7 ft	\$3,596.00	\$1,438.40	\$1,330.52
1630		10 ft	\$3,680.00	\$1,472.00	\$1,361.60
1640		14 PI	\$3,765.00	\$1,506.00	\$1,393.05



**TERMS AND CONDITIONS OF SALE**

**\*\*\*\*EXTRA discount only applies to orders over \$50,000 at retail price. I. General:** All orders shall only be accepted and executed based on the following conditions. Any opposing terms stipulated by the buyer are invalid and need no objection from the seller. During an ongoing business relationship, these conditions shall also be considered part of the contract unless expressly referred to by the individual contract. The possible invalidity of individual provisions of these terms and conditions has no influence on the rest. Any verbal agreements or changes to these terms shall only be valid under a written agreement. **II. Purchasing process**

**1. Offers** All offers with respect to price, quantity, delivery period and availability are subject to change. Brochures, illustrations, drawings, measurements and weights are not binding. **2. Prices** The prices are FOB Factory and excluding the applicable TAXES. They do not include packaging, transportation, installation or any other costs. The delivery occurs at the prices and conditions valid on the day of shipment. **3. Shipment** Even with free delivery, the shipment occurs at the risk of the receiver; dispatch and delivery are selected by the shipping company. Purpose-appropriate packaging is provided by the seller with due care, but without assuming any liability. The risk of the goods sold passes to the buyer once the seller has delivered the goods to the shipper, carrier-manager or any person or institution otherwise assigned to execute the dispatch, at the latest from leaving the factory or warehouse, which even applies when special instructions are provided by the buyer. **4. Delivery** volume For all orders, the seller is entitled to perform and charge partial deliveries that must be paid respectively after the expiration of each invoice. **5. Delivery period** Delivery periods are defined by the seller at its discretion, and set so that they can be met in all probability. Should any delays occur in delivery, the seller recognizes no claims for damages or withdrawal from the purchase. **6. Retention of title** The seller retains title to all goods delivered by him and any new goods resulting from the processing, combining or mixing of these goods until all claims against the buyer, including the current account balance, the interests and costs in any litigation, are met. Should the seller in the case of default or the risk of property claim enforce his reservation of title, this shall not constitute a rescission of contract. The buyer is obliged to inform the seller of any seizure or other impairment of the conditional ownership immediately in writing etc. and to inform the pledger about the subject retention of title. Any disposal of goods delivered outside of normal business activities, e.g., by pledging, security transfer or lending is prohibited to the buyer. In the event of default by the buyer, the seller has the right to enter the premises or places where the items delivered are located and take over these without any enforceable title, even if they are fixed to the building or space. Removal costs or damage to the floor shall be borne by the buyer. **7.**

**Liability** for defects and damages The buyer shall check the delivered goods immediately upon receipt and report any shortcomings and omissions in writing within eight days. The defects reported within the deadline can only be considered once the buyer can prove that the defect is not due to incorrect installation, improper commissioning, disorderly operation or handling of the goods. A warranty on applicability of the goods for the intended purpose cannot be accepted. Any advice on technical application, operating instructions and the like are not binding and do not exempt the buyer from examining the product for its suitability for intended purposes and procedures. If an onsite preparation is required for some machines, equipment or other facilities, such as creating concrete foundation, this always occurs at the buyer's expenses. Should any work be necessary, this shall be arranged by the buyer even when the seller accepts the mounting or contracts a third party. A return of goods may only take place if the seller has agreed the return of goods in writing. If a return occurs without seller's consent, the goods in question shall be stored at the expense and risk of the buyer. The seller assumes no responsibility or liability for accidents with persons involved, damage or operating malfunctions or defects, which arise in connection with the delivered goods. In any case, the seller is only liable for the damages under its own warranty claims against the respective supplier. At the request of the buyer, the seller cedes him his own warranty claims.

**III. Payment terms** 1. Payment is due 30 days following the date of invoice. In the case of cash payment within 8 days after the invoice date, a 2% discount is granted on the prices of commodities, if all the seller's previous claims towards the buyer are met. A date no later than the date of shipment applies as the invoice date. Any invoices concerning assembly, repair and maintenance or spare parts are payable immediately and without deduction. No discount is granted for invoices to retailers for amounts under \$100. 2. Under all circumstances, the seller reserves the collection of its own or other acceptances. Any bills of exchange or cheques can only be accepted as payment if any additional costs are borne by the buyer. No discount is granted for payments with bills of exchange. Should a bill of exchange or cheque given by the seller become object of a protest, all still outstanding payments are due immediately. Additional bills of exchange or checks with later maturities shall be paid by the buyer immediately and in cash. Once the payment is due, the buyer shall pay the default interests in the amount 8% above the current state central bank discount rate.3. No withholding or offsetting by the buyer due to any counter claims is permitted.4. The seller remains at any time entitled to cancel a lending – also within the terms of payment in accordance with the terms of payment presented. The seller is also entitled to demand a sufficient security at any time, without notice or justification. Without such a security, the payment is due immediately. 5. Should the seller provide any inputs in the form of cash payment, etc., no interests shall be charged. IV. Fulfillment and jurisdiction The place of legal representation and jurisdiction for both parties is Montreal, Quebec, Canada